



Product overview

The AX-OC-MWS-3 microwave occupancy detectors provide automatic control of lighting, heating or ventilation loads. These units detect movement using a highly sensitive microwave detector. Low power microwave signals are emitted and the reflections measured as the signals bounce off moving objects. The AX-OC-MWS-3 has an adjustable sensor head that allows the area of detection to be optimised for the application, and is intended for longer distance corridor type detection. When movement is detected the load is turned on. When an area is no longer occupied the load will switch off after an adjustable time out period. An internal light sensor provides additional energy saving advantages. When an area is occupied lighting is only switched on when the level of natural light is below a preset level. An integral infra-red sensor allows programming of the settings and the sensor to be overridden using a remote control handset.

Features

- Variety of Supply / Output Options
- Hand Held Programmer for fast commissioning
- Up to 30m detection range (e.g. along corridors)
- Presence or absence detection modes
- Movement and Light level built-in

Product specifications

Sensor Type:	Microwave and Light Level
Power Supply:	-3 & -3VF 220-240Vac 50Hz
	-3L & -3LVF 11.5 to 36Vdc or 10 to 26.5Vac. 1100mW maximum
Contact Rating:	NO 10A, 240Vac maximum resistive and incandescent lighting -6A, 240Vac fluorescent
	NC 3A, 240Vac low energy lighting, compact fluorescent lighting, fans
	2A, 240Vac maximum resistive (on VFC versions only)
Field of View:	See diagram
Delay Timer:	Adjustable 10 seconds to 99 minutes
Terminals:	For 0.5-2.5mm ² cable
Ambient Temp. Range:	-10 to +35°C
Housing:	Flame retardant ABS, fixing clip polypropylene. IP40
Microwave Radiation:	Extremely low power complies with ANSI IEEE95.1-1999
Microwave Frequency:	10.687GHz approved for use in UK, Middle East, China, India (alternative frequencies available for other countries - please enquire)
Conformity:	EMC: 2004/108/EC, LVD: 2006/95/EC
Weight:	150g
Country of Origin:	United Kingdom

Order codes

AX-OC-MWS-3	Ceiling Mount Microwave Occupancy Detector - 230V, switched live output
AX-OC-MWS-3VF	Ceiling Mount Microwave Occupancy Detector - 230V, volt free output
AX-OC-MWS-3L	Ceiling Mount Microwave Occupancy Detector - 24V, switched supply output
AX-OC-MWS-3LVF	Ceiling Mount Microwave Occupancy Detector - 24V, volt free output
AX-OC-MWS-UHS	Remote Programming/Commissioning Handset

Order Online at:
www.annicom.com
Email orders and enquiries to:
Sales@annicom.com

© Copyright Annicom 2017. All Rights Reserved

Annicom Ltd

Unit 21, Highview, Bordon, Hampshire. GU35 0AX
Tel: +44 (0)1420 487788 Fax: +44 (0)1420 487799

Email: sales@annicom.com Website: www.annicom.com

AX-OC-MWS-3

Microwave Occupancy Detectors - Ceiling mount (for 'Corridor' use)



Dimensions

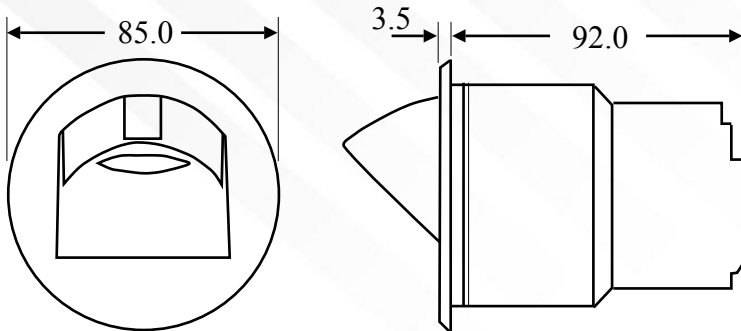

Detector pattern

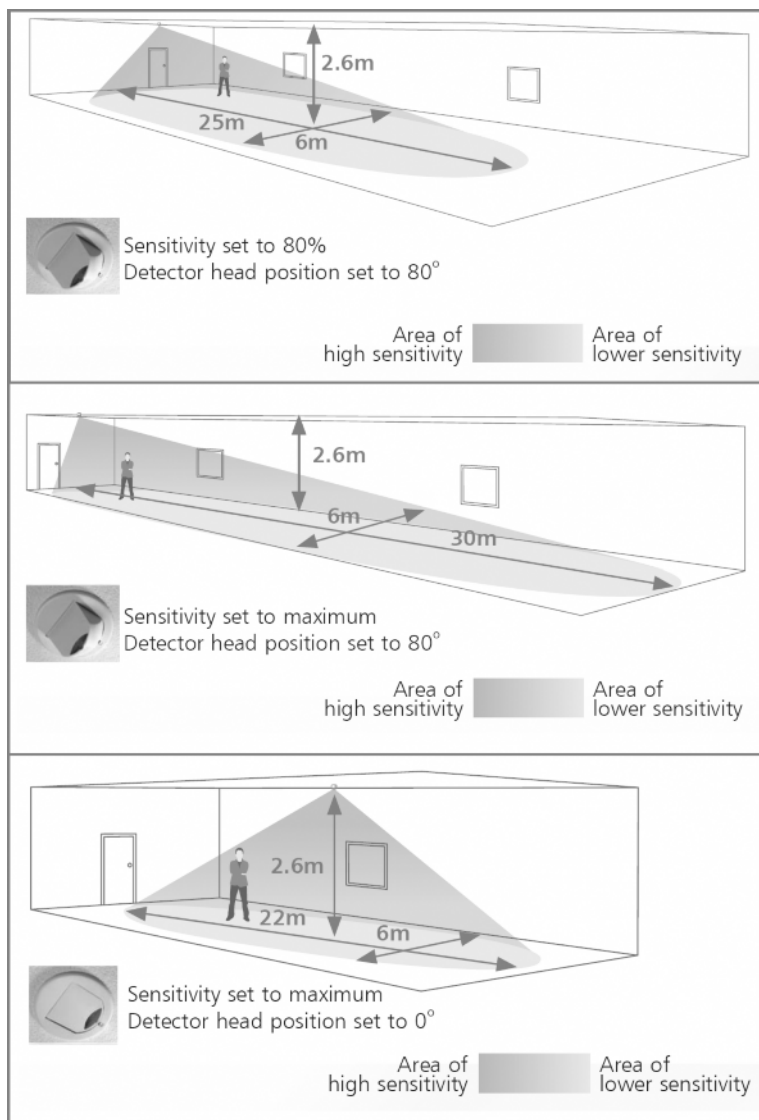

Installation

The detector should be sited so that the occupants of the room fall inside the detection pattern shown overleaf, at a recommended ceiling height of 2.6m.

Corridors or aisles: The unit should be placed at the end of the corridor or aisle and the sensor head should be angled to look down the corridor or aisle.

Open plan areas and offices: The unit can be mounted in a corner looking outwards in which case the sensor head should be angled. Or the unit can be mounted in the centre of the area with the sensor head flat. Note that the higher the sensor is installed the shorter the detection range will be.

- Do not site within 1m of any lighting or ventilation equipment.
- Do not fix to a vibrating surface.
- Site as far away as possible from the surface of metal objects.
- A 74mm diameter hole in is required for flush fixing.

Warning. This device works at mains potential. Be sure to take care when working with electricity.

1. Ensure the load is connected and in working order.
2. Isolate the mains supply to the circuit.
3. Connect the controller via the terminal block. Live supply to the L terminal, Neutral to the N terminal and the load to the L/OUT terminal.
4. To switch from more than one position simply wire two or more units in parallel to achieve two way and intermediate switching.
5. Swing the sensor head down using the finger slot to expose the settings.
6. Use a small screwdriver to set the LUX level adjuster fully clockwise, the time to minimum (fully anticlockwise) and the sensitivity to maximum (fully clockwise) - refer to the diagram.
7. Apply power - the load should come on immediately.
8. Vacate the room or remain very still and wait for the load to switch off (Should take no more than 2 minutes). Check that the load switches on when movement is detected.
9. To set the LUX level wait until the level of natural daylight is just enough that lighting is required. Starting with the LUX adjuster fully anti-clockwise. Very slowly turn the adjuster clockwise until the lights come on. Note that when the LUX adjuster is fully clockwise then the lights will **always** come on with occupancy. (With remote handset: LUX setting can be done using the lux up and lux down buttons)
10. Select the time-out range using the adjuster - fully clockwise is the maximum.
11. The area of detection can be varied by altering the angle of the sensor head and also the sensitivity adjuster. Note: on maximum sensitivity this unit is extremely sensitive to movement and may detect through thin walls on partitions. If this causes a problem reduce the sensitivity by turning the adjuster anticlockwise.
12. Remote handset: the override-on button turns the unit on permanently; the override-off button turns the unit off permanently; the cancel button cancels the overrides. When an override is selected the LED behind the lens will flash.

AX-OC-MWS-3

Microwave Occupancy Detectors - Ceiling mount (for 'Corridor' use)



Installation Instructions

Cut out 74mm dia. hole

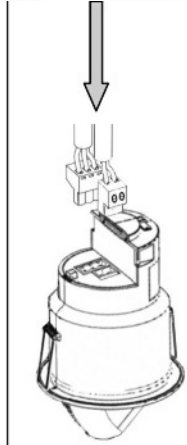
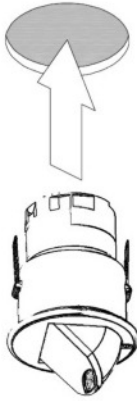

Attach cable clamp

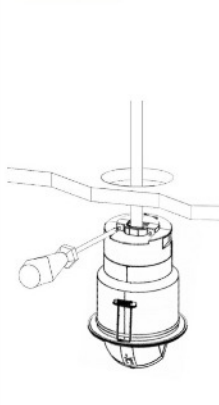

Take care when bending springs

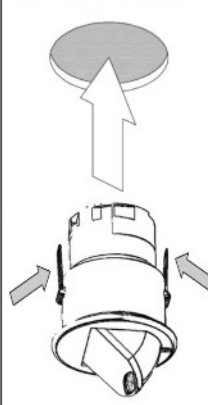

Locking the head:

Remove metal locking pin from rear of unit

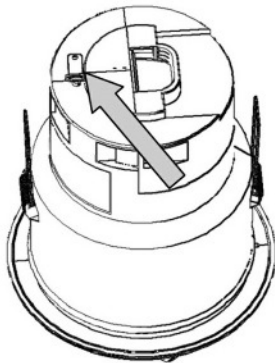

Adjust the head to the required position

Push clip in to position shown to lock the head

The clip can be removed by levering out with a small screwdriver

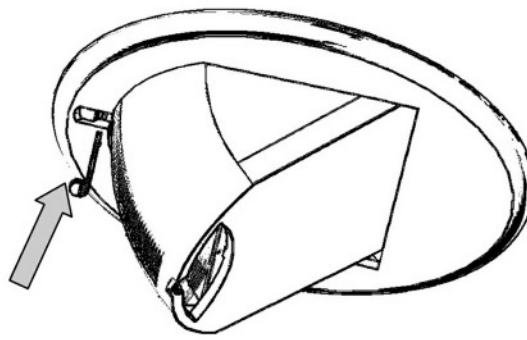

Adjustments

Slide open the window

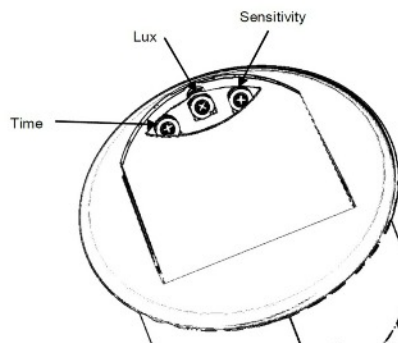
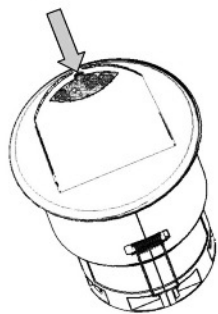

AX-OC-MWS-3

Microwave Occupancy Detectors - Ceiling mount (for 'Corridor' use)



Connections:

AX-OC-MWS-3

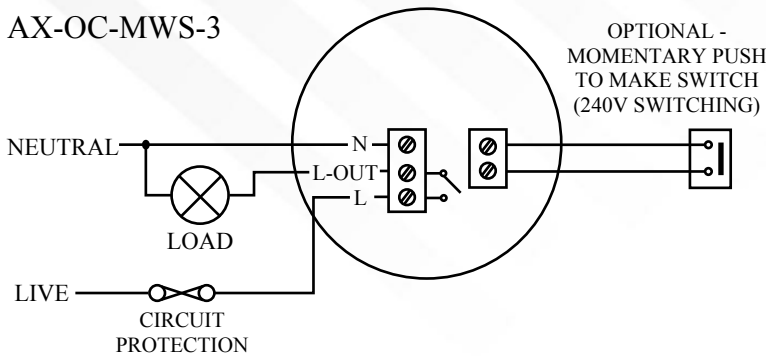

AX-OC-MWS-3L

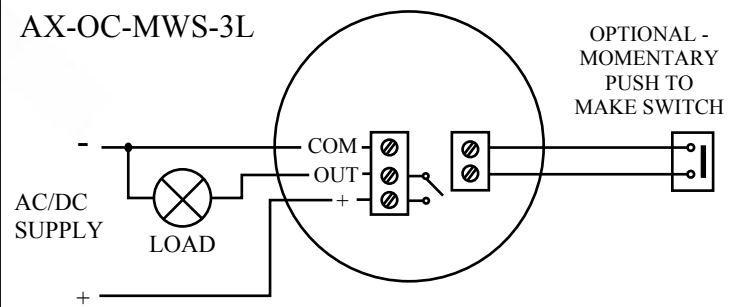

AX-OC-MWS-3VF

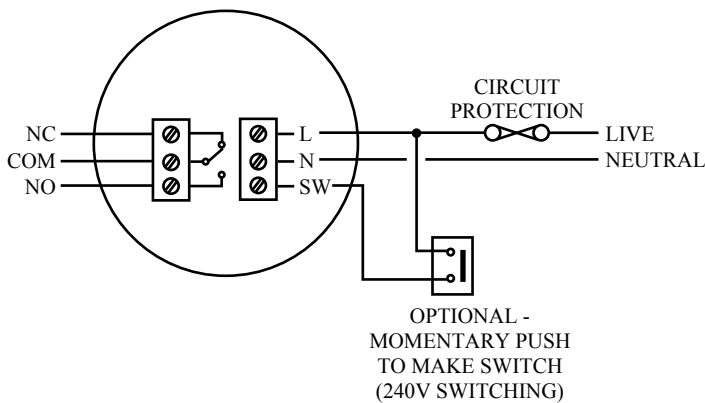

AX-OC-MWS-3LVF

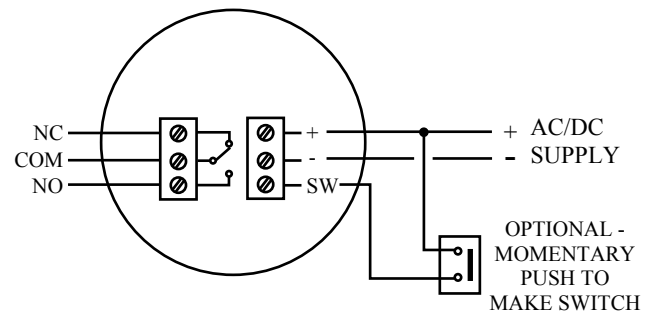

Two modes of operation are possible:

Presence detection:

When movement is detected the load will automatically turn on (subject to the light level setting). When no movement is detected, the load will switch off after the adjustable time period. If an external push switch is connected, this can override the lights off (after the detection time period has elapsed the unit will revert to automatic operation).

Absence detection:

The load is manually switched on using an external push switch. When no movement is detected, the load will switch off after the adjustable time period. Pressing the switch again during occupancy will override the lights off (after the detection time period has elapsed the unit will revert to automatic operation).

In both modes of operation, a short button press turns the load on, and a long button press turns the load off.

The unit ships with presence detection as default. To change to absence detection press and release the external switch 5 times within the first minute of power up. The LED behind the lens will turn on solid for 30 seconds to show absence mode has been selected. To change back to presence detection, repeat the above procedure. The LED behind the lens will turn flash for 30 seconds to show presence mode has been selected.

Remote handset

The above adjustments together with time-out, light level and sensitivity can all be made with the Remote Handset.

Fault Finding:

Load will not switch on:

Check to see if the live supply to the circuit is good. Strap across the *L* and *LIVE OUT* terminal to turn the load on. If the supply and wiring are good, check the LUX level setting. Increase the LUX level setting to allow the controller to turn on at higher ambient natural light level.

Load will not switch off:

Ensure that the area is left unoccupied for a greater time period than the time out period set using the switch. Make sure that the sensor is not adjacent to vibrating surfaces or objects (e.g. ventilation equipment). The unit may pick up movement through thin partitions or walls, or movement that occurs behind the sensor. Reduce the sensitivity by turning the adjuster anticlockwise.

Every effort has been taken in the production of this data sheet to ensure accuracy. Annicom do not accept responsibility for any damage, expense, injury, loss or consequential loss resulting from any errors or omissions. Annicom has a policy of continuous improvement and reserves the right to change this specification without notice.