

AX-MPR1-2-24

2kW Single phase Power Regulator



Product overview

The AX-MPR1-2-24 DIN Rail mounting Power Regulator (thyristor) provides continuously adjustable control of electric heating loads from a 0-10V control input. Applications include electric heating coils, heating cables and electric furnaces. The AX-MPR1-2-24 uses solid-state switching with "zero crossing technology" for minimum RFI and provides accurate switching control. The unit features over temperature protection with automatic reset and LED indication of output operation. The module enclosure clips on to TS35 section DIN Rail. No additional heatsinks are required.



Products Features

- 0-10Vdc Control Input
- 2kW Nominal Heater Duty
- Neutral Pass Through Terminals
- Auto-Reset Over-Temperature Protection
- 24Vac/dc Powered
- Burst-fire Control
- LED Indication of operation
- DIN Rail (TS35) Mounting

Product Specifications

Input:	0-10Vdc at 0.2mA maximum
Nominal Heater Duty:	2kW
Load:	8.7A maximum @40°C
Dissipated Heat:	12W maximum
Power Supply:	24Vac/dc ±10%
Power Consumption:	30mA @ 24Vdc (0.72VA) or 50mA @ 24Vac (1.2VA)
Alarm Output:	24Vac/dc (as power supply) - open-circuit when over temperature alarm is active
Rated Supply:	220-255Vac / 50-60Hz
LED Indication:	ON when output is on
Terminals:	Rising clamp for 0.5-1.5mm ² stranded or 2.5mm ² solid core cable
Ambient Temperature Range:	0 to 55°C Note; The units are rated at 40°C. If using at higher ambient temperature derate the units by 10% for every 5°C above 40°C
Over temperature:	Load is disconnected when heatsink temperature exceeds 90°C. Load is reconnected when heatsink temperature falls below 85°C
Dimensions:	82x56x50mm
Weight:	95gms
Country of Origin:	United Kingdom

Order codes

Part number	Description
AX-MPR1-2-24	2kW Single Phase Power Regulator 24V powered

AX-MPR1-2-24

2kW Single phase Power Regulator



Operation

The AX-MPR1-2-24 controls electric heating loads in linear proportion to the applied 0-10Vdc control signal. Solid-state semiconductor devices switch the load using burst-fire control, combined with zero-crossing point switching which virtually eliminates RFI emissions.

Burst-fire control is where the ac load is switched fully on for an integer number of complete half cycles in a burst. Assume a cycle time of 4 seconds: With a 0-10Vdc Input Signal of 10V the load will be on all of the time i.e. fully ON. At 5V input the load will be switched ON for 2 seconds and OFF for 2 seconds, i.e. on average the load is at 50% power. At 2.5V input the load will be switched ON for 1 second and OFF for 3 seconds, i.e. on average the load is at 25% power. Note that whenever the load is switched ON, full load current will be drawn for that period of control time.

Installation and configuration

The AX-MPR1-2-24 Power Regulators mount on a TS35 Section DIN Rail and must be installed with their heatsink cooling fins in a vertical plane. (Refer to connection diagram). Allow a minimum of 100mm between units mounted in a vertical plane.

CAUTION

In normal operation the heatsink surface can exceed 90°C. Dangerous potentials exist on the PCB and particular care should be taken.

Electrical Installation

Installation must be carried out by a suitably trained electrician, and in accordance with the relevant statutory regulations in place.

Load Supply and Back-up Protection

It is recommended that a load disconnect switch and a contactor are installed in the load supply. The supply to the contactor coil should be interrupted by sensors for over temperature in the heater and also upon air flow loss. Fuses or MCB's (miniature circuit breakers) are required to provide back-up protection. High Speed Fuses will protect the solid-state switching devices against short circuit currents.

Maximum Heating Load

The power rating of the units are given as a guide. The maximum current (which is dependant on the actual supply voltage and heating load) as shown in the specification table must not be exceeded.

Control Signal

All low voltage signal and supply cables should be kept separate from high voltage or mains cables, separate trays or conduit should be used. Screened cable should be used for connections to BMS Controllers. Where possible the cable screen should be connected to a functional earth (not mains safety earth). The screen should be earthed at one end only to avoid earth loops.

Connections

Showing correct orientation of heatsink fins

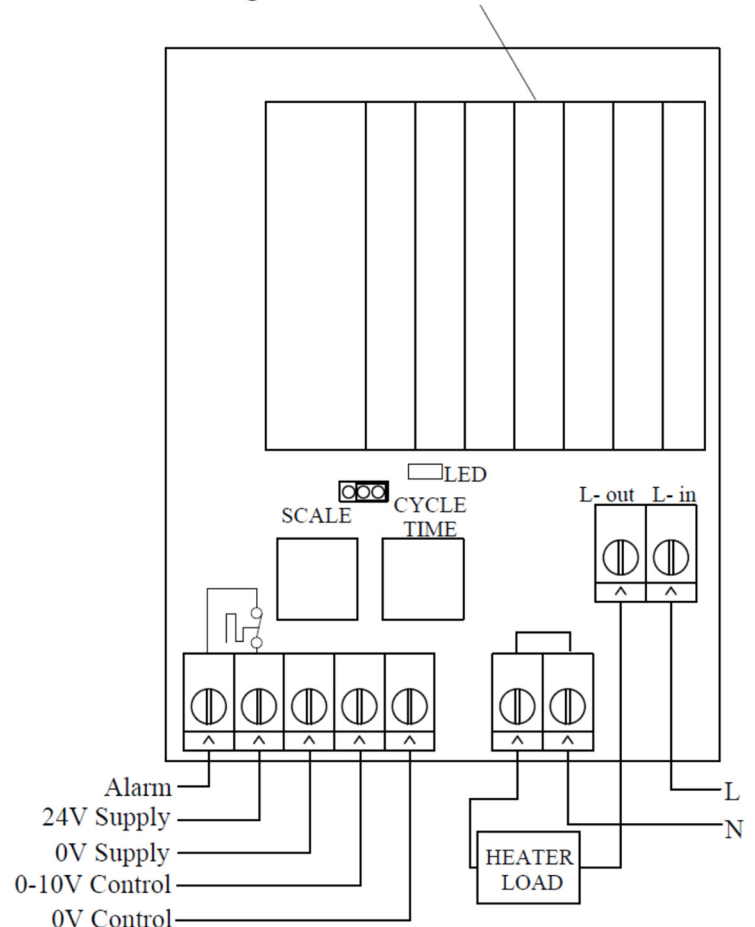

NOTE: It is imperative that the power connections are fully tightened, without excessive force, and ensure the maximum area of cable is in contact with the terminals.

Ventilation

The ambient temperature of the installation should not exceed 55°C. If necessary, enclosures or control panels should be ventilated with a cooling fan. See note in product specification for de-rating to be applied above ambient temperatures of 40°C.

Cycle Time

The Cycle Time is preset for 4 seconds. Adjustment is possible using VR2, but is not normally required.

Signal Rescaling

A 0-10Vdc Input Signal of 5V equates to the load being 50% ON. At 2.5V input the load will be 25% ON. At 10V input the load will be 100% i.e. full ON. Adjustment is possible using VR1, but is not normally required.

Manual Override

The module is supplied preset to the Auto position. It is possible to manually override the input signal by placing the M/A Jumper in the M position. In this position the load will be 100% ON. The output load can be adjusted downwards using the signal rescaling facility. (See above).

Datasheet Contents

Every effort has been taken in the production of this data sheet to ensure accuracy. Annicom do not accept responsibility for any damage, expense, injury, loss or consequential loss resulting from any errors or omissions. Annicom has a policy of continuous improvement and reserves the right to change this specification without notice.

Over Temperature Monitoring

An electronic thermal cutout is fitted to the heatsink to protect against over temperature. The AX-MPR1-2 will switch off the load if the heatsink temperature exceeds approximately 90°C and will reconnect the load once the heatsink temperature has dropped below 85°C. Under normal operating conditions the heatsink temperature will not reach 90°C but this might occur, for example, if the ambient temperature exceeds 40°C.