



Product Overview

The AX-EWSS wind speed switch is designed to either activate or deactivate an external device at a user defined wind speed level. This is suitable for applications such as automatic window closure and outside air damper control. The units are manufactured from anodized aluminium alloy, UPVC and stainless steel with moulded polypropylene cups. The units are lightweight (less than 200 grams) yet very robust.

Features

- Wind Speed Switch
- Damped output for a stable control signal

Product Specifications

| | |
|--|---|
| Electrical Connections: | 25m cable (max 200m) |
| Supply Voltage to Control Box:: | 12Vdc |
| Wind Speed: | |
| Sensor | Hall effect solid state magnetic switch |
| Range | 0-50m/sec |
| Output: | SPDT Relay |
| Output Rating: | 5A |
| Min start speed: | 0.5m/sec |
| Accuracy: | +/-5 % or 1.5m/sec |
| Threshold | <1.5m/sec |
| Ambient Temp. Range: | -20 to +60°C |
| Weight: | <200gms |
| Protection: | IP65 |
| Country of Origin: | United Kingdom |

Order Codes

AX-EWSS Wind Speed Switch - 5A SPDT Relay o/p
 comprising: 1 x wind speed sensor
 1 x Control Box
 25m sensor cable

Siting

It is important to choose a site carefully to mount the unit. Sheltered sites should be avoided, as should exposed sites unless there is a requirement to measure wind speed under exposed conditions. Mounting on the wall of a building may also shelter the unit, leading to inaccurate readings.

It should be noted that the windspeed increases exponentially with the height above the ground, for the first 20 metres. It follows that mounting on a tall mast will lead to higher windspeeds. A good recommended height is between 2 and 9 metres above ground, where possible.

Mounting on a flat roof should also be avoided as this can lead to inaccurate readings due to turbulence and eddies. If the unit is to be mounted near to the ground, anti-vandalism measures may be required. Any protection of this nature should not obstruct the windflow to the unit.

Mast

The units are designed to be mounted to a mast of between 30-50mm diameter by means of a V shaped clamp and bracket.

Connection

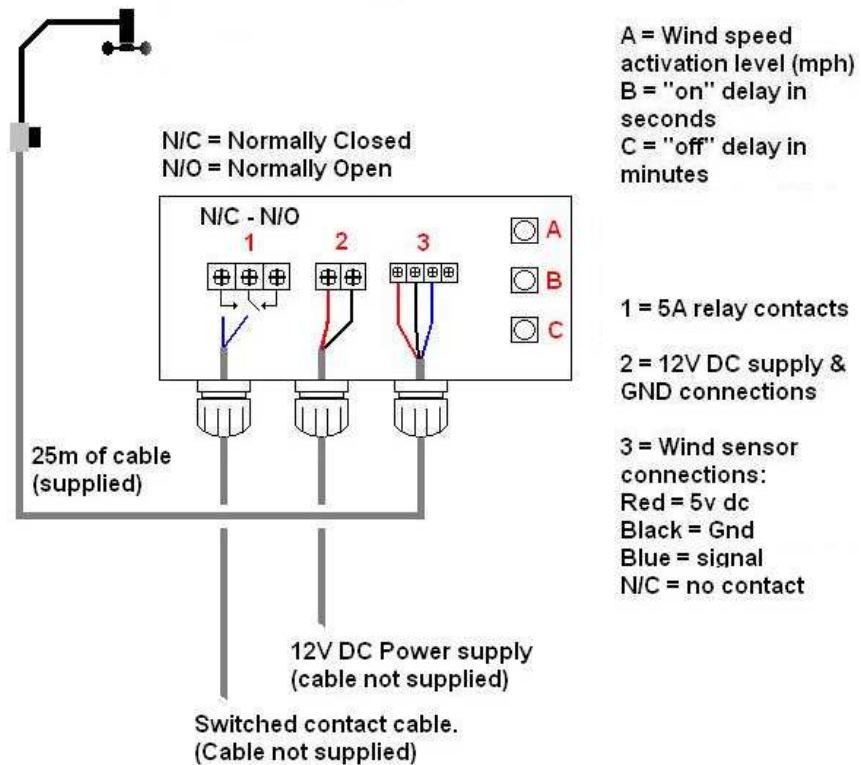

Control Box Mounting

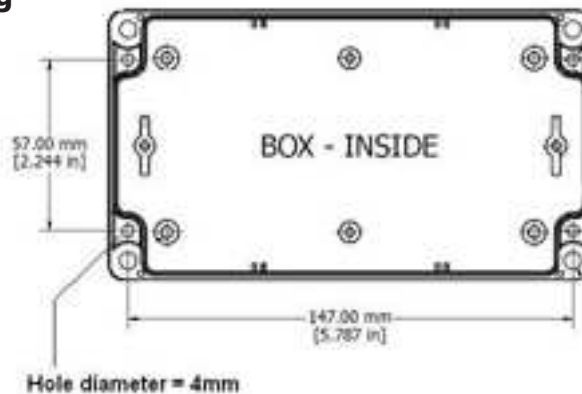

Every effort has been taken in the production of this data sheet to ensure it's accuracy. Axio can not, however, accept responsibility for any damage, expense, injury, loss or consequential loss resulting from any errors or omissions. Axio has a policy of continuous improvement and reserves the right to change this specification without notice.