



Product Overview

The AX-CNDR-X3 range of Digital Room Controllers feature a high-contrast blue backlit display with white text, and fit a standard single gang pattress.

The unit has an internal temperature sensor and provides an adjustable proportional and integral heating or cooling output or On/Off control with hysteresis. Relays provide 3 speed fan control with manual or auto speed selection.

Features

- 0-10V PI heating or cooling
- 3 fan speed relay outputs with Auto
- Adjustable setpoint range
- Fits a standard single gang deep back box
- Two part plug-in connectors for easy installation
- Actuator supply (A version)
- Independent heating/cooling relay (XR3 version)
- 0-10V Fan speed output (XEA version)

Order Codes

AX-CNDR-X3	0-10V heating or cooling, 3 fanspeed relay outputs, 24Vac supply
AX-CNDR-X3-230	0-10V heating or cooling, 3 fanspeed relay outputs, 230Vac supply
AX-CNDR-X3A-230	0-10V heating or cooling, 3 fanspeed relay, 24Vdc actuator power outputs, 230Vac supply
AX-CNDR-XEA-230	0-10V heating or cooling and fans, 24Vdc actuator power outputs, 230Vac supply
AX-CNDR-XR3-230	On/Off heating or cooling, 3 fanspeed relay, 230Vac supply

Product Specifications

Power Supply:	24V 24V - 24Vac/dc 230V - 90-265Vac
0-10V Heat/Cool/Fan output:	0-10Vdc at 5mA maximum
Fan Relays/Heating/Cooling:	3A resistive at 250Vac
Actuator supply (A version):	24Vdc, 190mA, 4.6W
Finish (Plate):	Brushed Stainless Steel
Weight & Dimensions:	250gms (approx) 86 x 86 x 35mm (approx)
Backbox Depth:	45mm
Ambient Temperature Range:	0°C to 60°C
Country of Origin:	United Kingdom

© Copyright Annicom. All Rights Reserved

Annicom Ltd

Unit 21, Highview, Bordon, Hampshire. GU35 0AX

Tel: +44 (0)1420 487788 Fax: +44 (0)1420 487799

Email: sales@annicom.com Website: www.annicom.com

Installation

The unit should be installed by a suitably qualified technician in conjunction with any guidelines for the equipment it is to be connected to and any local regulations. Field wiring should be installed to satisfy the requirements set out by the manufacturer of the equipment that the module is being connected to.

Menu

Follow the steps below to enter the menu, listed options not available on all units

The engineering values can be viewed but not adjusted until two password values 132 and 120 are selected in the correct sequence.

1. Press On/Off to switch unit off
2. Press and hold On/Off for 5 seconds. The display will change to the password option and display 128.
3. No changes allowed. Press On/Off switch to scroll menu, do not press any buttons for 10 seconds and the unit will return to normal operation.

or

- 3A. Press setpoint increase only to set value to 132.
- 3B. Press setpoint decrease only to set value to 120.
- 3C. Press setpoint increase, display shows 00.

3D Changes allowed. Press On/Off switch to scroll menu options described below. When required option is displayed press setpoint decrease or increase to adjust value or enable/disable option. When changes are complete do not press any buttons for 10 seconds and the unit will store new values and return to normal operation. Changes will be allowed for 10 minutes to reduce repetitive password entry.

Menu Options [Menu display mnemonic] (Default value)

Setpoint high limit [SPHi]

This sets the highest value the user can adjust the setpoint to. Range 25 - 30 °C. (28)

Setpoint low limit [SPLo]

This sets the lowest value the user can adjust the setpoint to. Range 15 - 20 °C. (18)

Temperature offset [OFSt]

This offsets the temperature from the calculated value. Positive values increase the temperature and negative values decrease the temperature. Range -10 to +10 °C. (0)

Operating mode [OPEr]

This sets the unit operating mode to heating or cooling. (H)

Proportional band [Pbnd]

This sets the heating and cooling proportional band. Range 1 - 30 °C. (5)

Fan band [Fbnd] (On/off only versions)

This sets the auto band for fan control. Range 1 - 30 °C. (5)

Integral time [Int]

This sets the heating and cooling integral time. Range OFF / 1 - 600 seconds. (200)

Fan speed steps [FnSt] (0-10V fanspeed version only)

This sets the number of steps that cover the output fan speed. For example selecting 10 will cause the output to change in 10 steps, 1 volt increments. Selection 3 / 10. (3)

Fans speed Low [FSLo]

When in 3 step mode this sets the fan speed low output voltage as a percentage, 33% = 3.3V etc. When in 10 step mode this sets the output voltage profile at a virtual step of 3.3. Range 0 to 50%. (33)

Fans speed Medium [FSnE]

When in 3 step mode this sets the fan speed medium output voltage as a percentage, 66% = 6.6V etc. When in 10 step mode this sets the output voltage profile at a virtual step of 6.6. Range 25 to 75%. (66)

Fans speed High [FSHi]

When in 3 step mode this sets the fan speed high output voltage as a percentage, 100% = 10V etc. When in 10 step mode this sets the output voltage profile at step 10. Range 50 to 100%. (100)

Setpoint switch actions [SPAc]

This enables or disables the setpoint buttons. (EN)

Fanspeed switch actions [FSAc]

This enables or disables the fanspeed buttons. (EN)

On Off switch actions [OnAc]

This enables or disables the on off button. (EN) (Menu entry will not be disabled)

Operation

The AX-CNDR-X3 controls room heating and cooling. The unit provides a 0-10V heating or cooling output relative to the setpoint and proportional band. If the integral time is set, the output will also vary with temperature error over time. The fan speed can be set manually or when auto is set, the fan speed is automatically controlled in 3 steps relative to the 0-10V heating or cooling output.

The AX-CNDR-XR3-230 provides on/off heating or cooling with a 0.5°C hysteresis factor. The fan speed can be set manually or when auto is set, the fan speed is automatically controlled in 3 steps relative to the proportional band.

User controls

On / Off

The user can switch the unit on or off. When the unit is off the cooling output will be zero and the fan is off. The On / Off switch actions can be disabled via the operating menu.

Setpoint

The user can adjust the setpoint between the Setpoint high and Setpoint low limits set in the menu. The Setpoint switch actions can be disabled via the operating menu.

Fitting and removing front plate

To fit front plate with the back plate fitted to the wall carefully bring front plate towards back plate and locate over the raised display then move plate to one side and clip over one side of back plate then push front plate in opposite direction and push front to clip onto back plate.

To remove front plate carefully insert slotted screwdriver into slot on side of thermostat and lever forward making sure plate does not fall.

Fan speed

The user can set the fan speed to low/med/high or auto. When auto is selected the fan speed will be set relative to the 0-10V heating or cooling output. The fan speed is displayed in three steps on the bottom display bar. The Fan speed switch actions can be disabled via the operating menu.

Connections

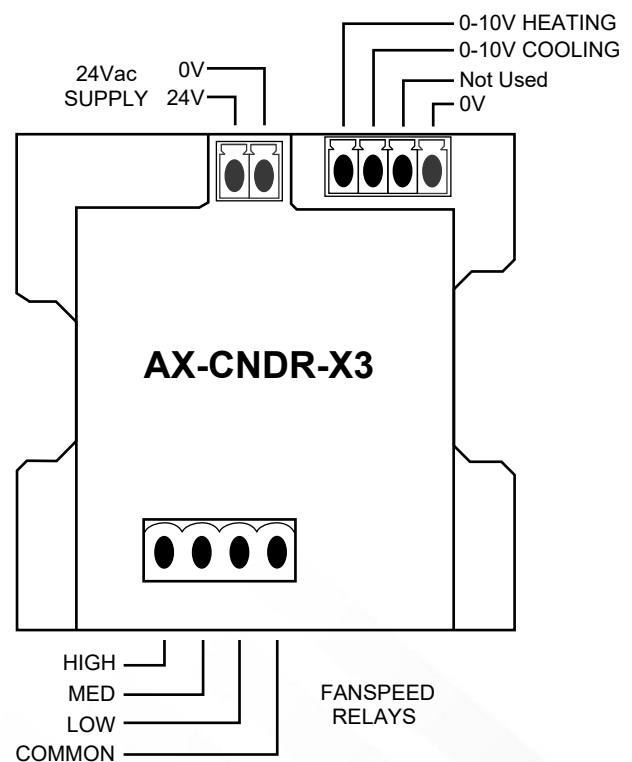

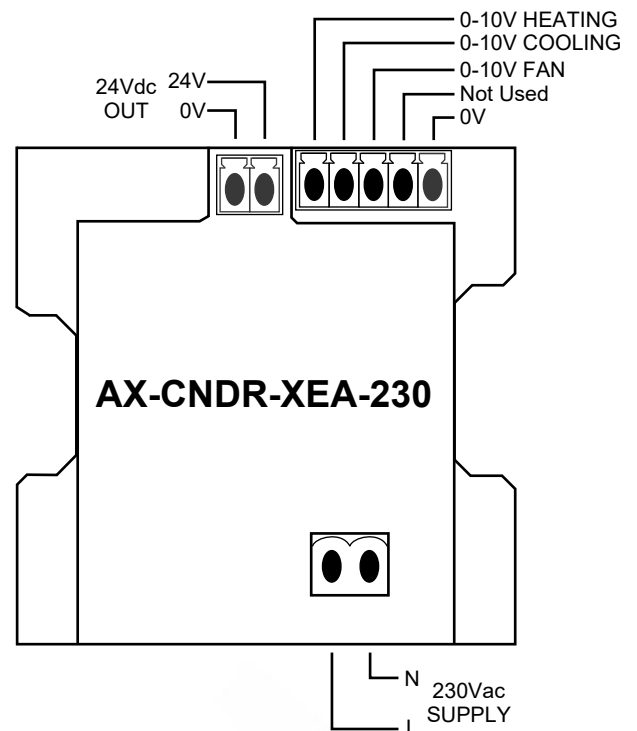
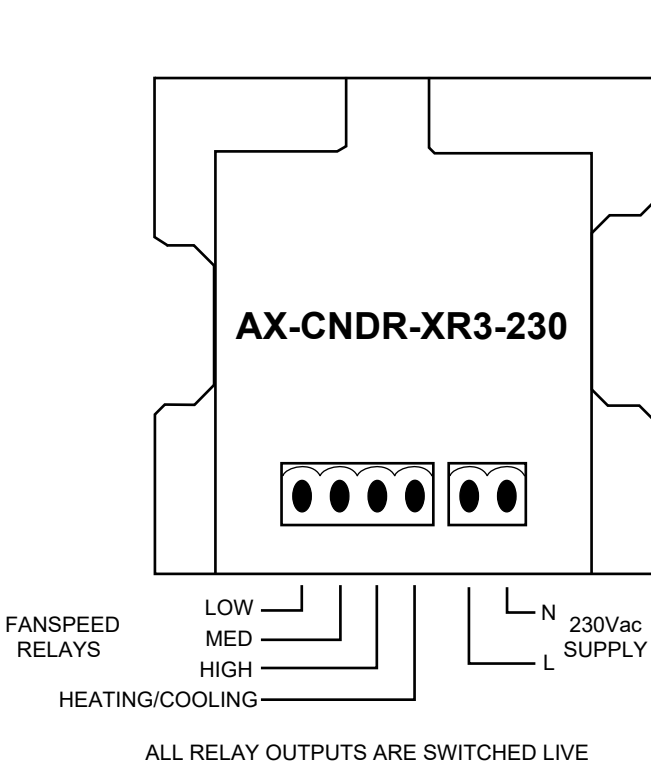
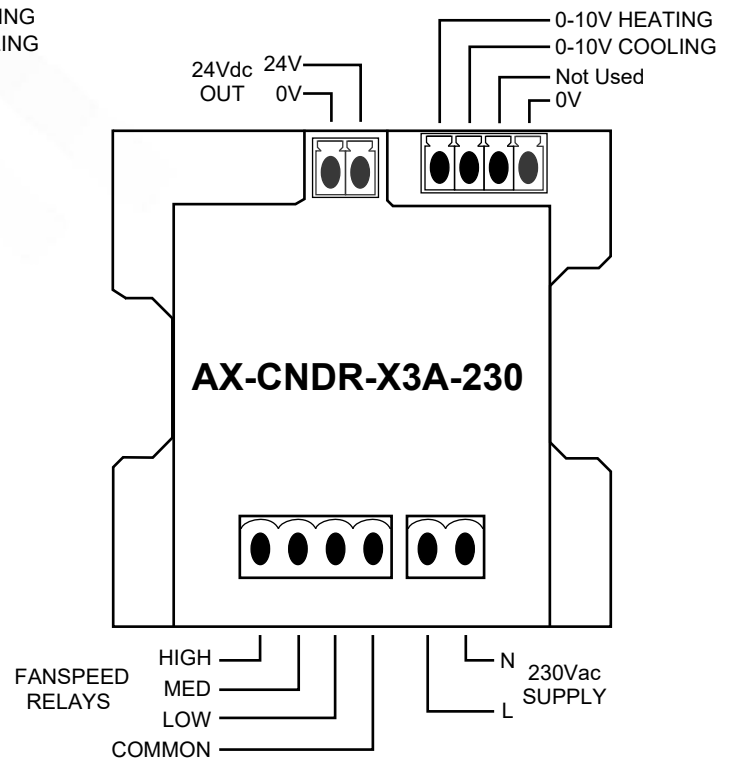
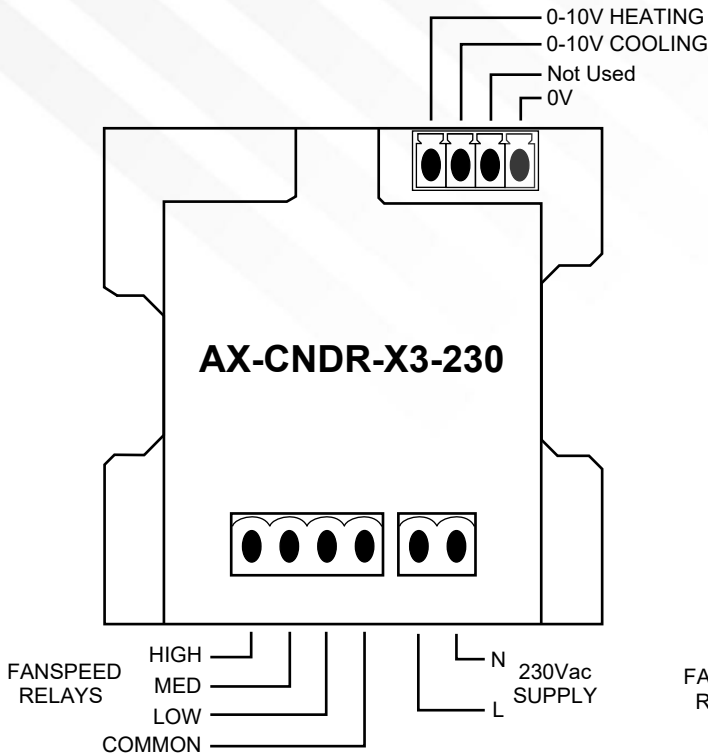

Datasheet Contents

Every effort has been taken in the production of this data sheet to ensure accuracy. Annicom do not accept responsibility for any damage, expense, injury, loss or consequential loss resulting from any errors or omissions. Annicom has a policy of continuous improvement and reserves the right to change this specification without notice.