

AX-AV-SP-ESF-35

Single Point Air Velocity and Duct Temperature Transmitter

AXIO



Product Overview

The AX-AV-SP-ESF-35 are single point air velocity transmitters designed on the Calorimetric principle of the air flow being passed across a heated thermistor and the results being measured against a control thermistor to determine heat loss and corresponding air flow. The units are mounted across the flow of the duct and give an analogue output proportionate to the air flow. Voltage or current output is available via jumper selection for both air flow and temperature. The device provides three jumper selectable ranges for air velocity; 2, 10 or 20m/s.

Features

- Proportional output for air velocity and temperature
- Includes Duct Flange
- Jumper selectable voltage or current outputs
- Optional LCD and Relay Output
- Jumper selectable speed ranges 2, 10 or 20m/s

Product Specifications

Power Supply:		24Vac / 24Vdc ±10% (120mA)
Airflow Speed:		0-2m/sec or 0-10m/sec or 0-20m/sec (jumper selectable)
Temperature Range:		0 to 50°C
Output Signal:	Velocity	4-20mA (max 400Ω) or 0-10Vdc (min 1kΩ)
	Temperature	4-20mA (max 400Ω) or 0-10Vdc (min 1kΩ)
Relay Output:		Volt-Free SPDT, 6A @ 250Vac / 6A @ 30Vdc
Ambient Temp. Range:		-20 to 70°C
Accuracy:	0-2m/sec	<0.2m/sec ±5%
	0-10m/sec	<0.5m/sec ±5%
	0-20m/sec	<1.0m/sec ±5%
	Thermal Shift	±0.8% FS/ °C
Dimensions:	Housing	90mm x 95mm x 36mm
	Probe	210mm x 10mm
Weight:		220g
Depth of Insertion:		50 to 180mm
Protection:		IP54
Country of Origin:		Finland

Order Codes

AX-AV-SP-ESF-35-3	Single Point Air Velocity Temperature Transmitter
AX-AV-SP-ESF-35-3D	Single Point Air Velocity Temperature Transmitter with Display
AX-AV-SP-ESF-35-3DR	Single Point Air Velocity Temperature Transmitter with Display and Relay

© Copyright Annicom. All Rights Reserved

Annicom Ltd

Unit 21, Highview, Bordon, Hampshire. GU35 0AX

Tel: +44 (0)1420 487788 Fax: +44 (0)1420 487799

Email: sales@annicom.com Website: www.annicom.com

AX-AV-SP-ESF-35

Single Point Air Velocity and Duct Temperature Transmitter



Installation

NOTE: In order to ensure optimum operating conditions the ESF sensor tip must be placed in the middle of the duct. To avoid airflow stratifications, which will adversely effect the sensor, the ESF should be placed at least 6 duct diameters in front of an obstruction or bend in the ducting, and not closer than 3 duct diameters behind an obstruction.

Maintenance

As the thermal measuring principle is based on the cooling principle of the air, possible dirtying of the sensor will reduce the measuring accuracy. If the transducer is used in unclean air, the sensor head should be cleaned at suitable intervals.

Mounting

The ESF-35 is mounted in such a way that the airflow passes the sensor head. The power supply cables to the transducer should be kept separated from high voltage lines where heavy transients may occur. The transducer can be mounted in airflow channels with a diameter or channel width of 100-370 mm

Wiring

The length of the cable is not critical. Avoid placing it in parallel with other cables, which may induce electrical noise on the voltage signal and thus disturb the function of the transducer.

The best installation is obtained with a separate cable to the transducer.

It is recommended to use a shielded cable to the transducer as

this will improve the immunity of the transducer against noise when it is used in industrial areas. The shield should be terminated at the supply point but not terminated at the transducer.

Connections

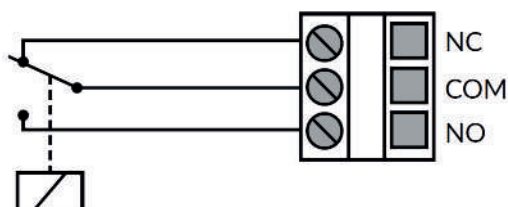
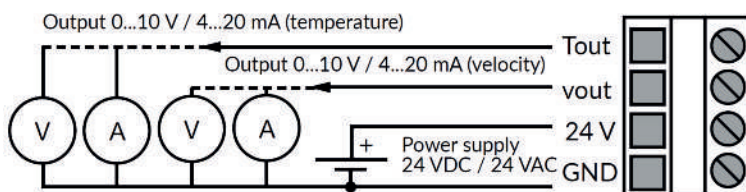

Dimensions

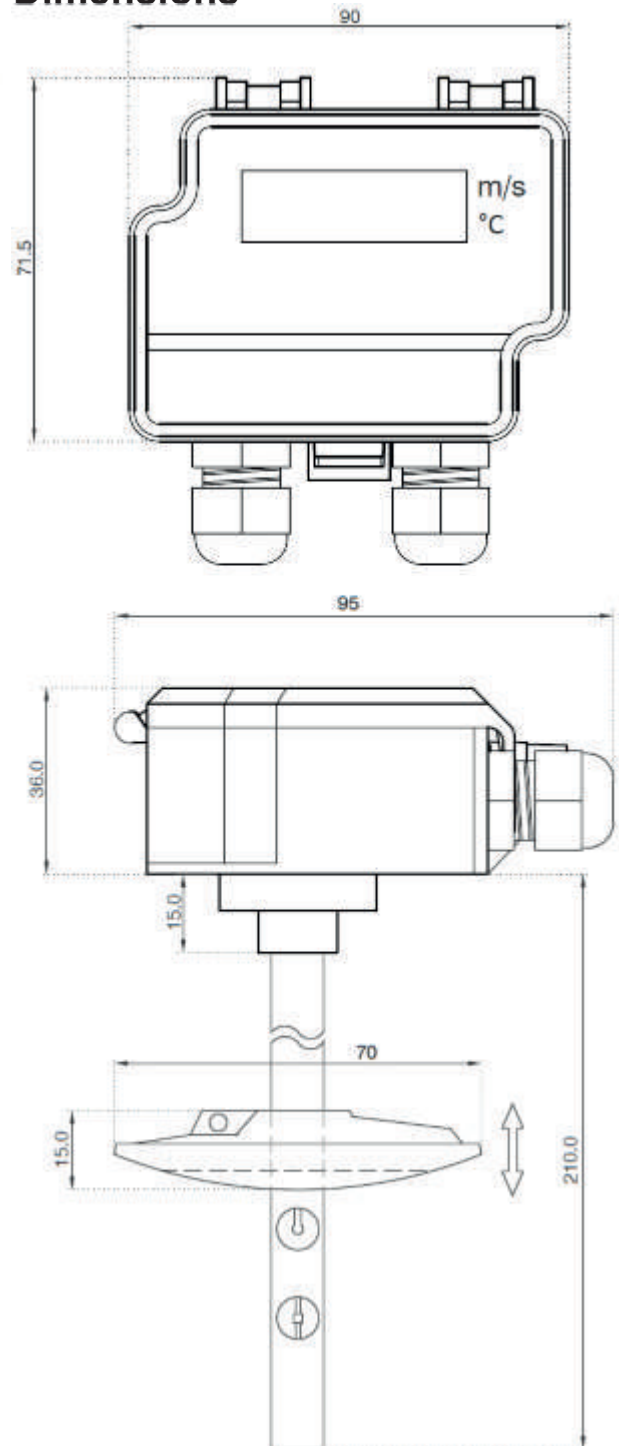

Datasheet Contents

Every effort has been taken in the production of this data sheet to ensure accuracy. Axio do not accept responsibility for any damage, expense, injury, loss or consequential loss resulting from any errors or omissions. Axio has a policy of continuous improvement and reserves the right to change this specification without notice.