



## Product Overview

The AX-ARM is an analogue rescaling module which accepts and analogue voltage or current signal and rescales it to another analogue range . several preset ranges are jumper selectable . the top-adjust trimming potentiometers can be used to make fine adjustments to the output range for maximum flexibility . The AX-ARM can attenuate an input signal to 100%.

The module also has an adjustable gain and offset . The output gain can be adjusted anywhere from 1 to 25 times the input ( the gain will vary depending on the input) on The Ax-ARM . The offset of the output can be adjusted anywhere from +/- .25 to +/- 20vdc for the module. The unit also has the ability to reverse the signal and also has a regulated DC power output to power sensors.

## Features

- Field adjustable ranges
- Reverse acting or direct acting output
- LED Status Indicator
- Din Rail Mounting option
- Plug in Terminals

## Applications

- Voltage// Current to Current Voltage conversion
- Resistance to Voltage/Current conversion
- Increase Analogue Input resolution
- Shrink or expand sensor ranges
- Reverse signals

## Product Specifications

<b>Inputs: Voltage</b>	0 to 35 VDC @ impedance 1 M ohms nominal
<b>Current</b>	0 to 44mA @ impedance 250 ohms
<b>Output: Voltage</b>	0.25Vdc min to 20Vdc max @impedance 3300Ω at 20V
<b>Current</b>	0 to 44mA, maximum output load 750Ω at 20mA
<b>Power Supply:</b>	24Vdc +/- 10%
	22 to 26Vac @50/60Hz
<b>Supply Current:</b>	200mA maximum
<b>Power Supply Output:</b>	20Vdc Nominal +/- 10% ( 30 mA max)
<b>Accuracy:</b>	Less than or equal to 1% of output span over full temperature range
<b>Signal Gain:</b>	1 to 25 times ( field adjustable)
<b>Signal Attenuation:</b>	0-100% ( field adjustable)
<b>Signal Offset:</b>	+/- 0.25 to 20 volts ( field adjustable)
<b>Signal Inversion:</b>	20 to 0.25V ( field adjustable)
<b>Terminals:</b>	45 deg captive screw
<b>Ambient Temp:</b>	0 to 50°C Humidity: 10% to 95% non condensing
<b>Dimensions:</b>	55(w) x 92.5(l) x 25(h)mm (max.)
<b>Weight:</b>	60gms (pcb only)
<b>Country of Origin:</b>	U.S.A.

## Order Codes

AX-ARM - Analogue Rescaling Module

**Installation**

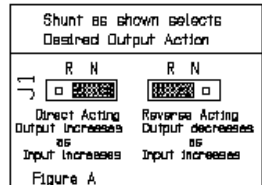
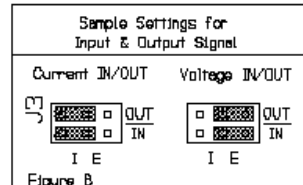
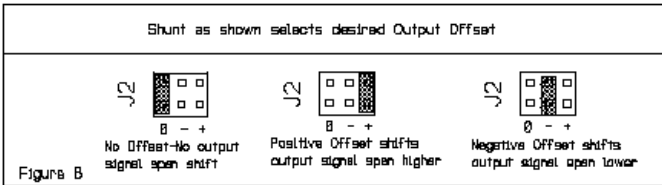
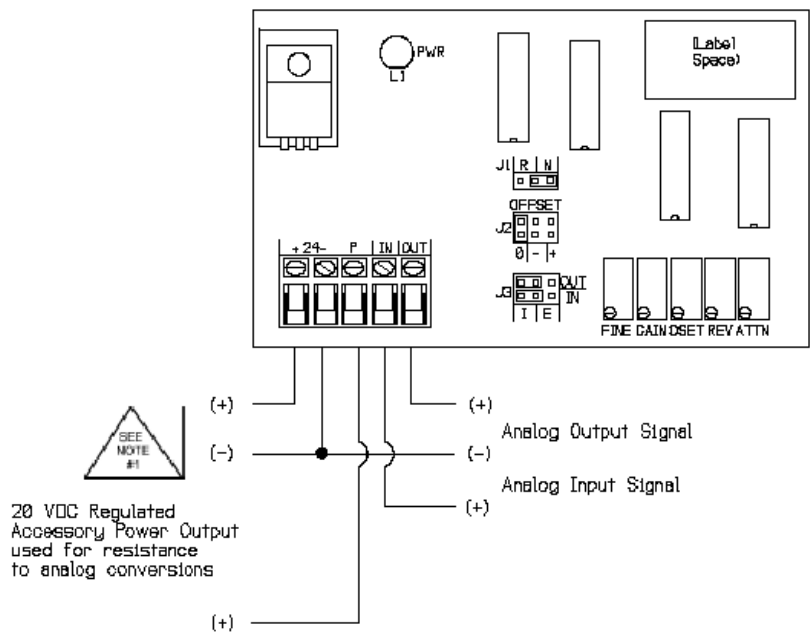
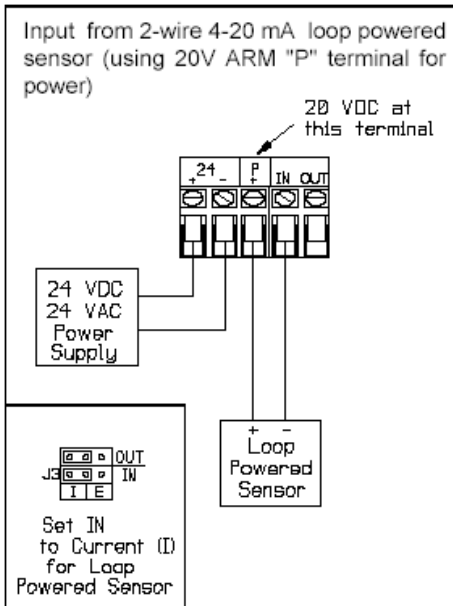

**READ THESE INSTRUCTIONS BEFORE YOU BEGIN INSTALLATION.**

Ground yourself before touching board. Some components are static sensitive.

**MOUNTING:**

Circuit board may be mounted in any position. If circuit board slides out of snap track, a non-conductive “stop” may be required. Use only fingers to remove board from snap track. Slide out of snap track or push against side of snap track and lift that side of the circuit board to remove. Do not flex board or use tools.

**POWER CONNECTIONS:**

- 1) **24 VDC** - with power off, connect 24 volt DC power supply to “24” (+) and (-) terminals on the board.
- 2) **24 VAC** - with power off, connect one transformer secondary leg to “24” (+) and the other to the common (-) on the board, along with signal input and signal output common (-). Check the wiring configuration of any other loads that may be connected to this transformer. Any field device connected to this transformer must use the same common. If you are not sure of other field device configuration, use separate transformers.
- 3) **If the 24 volt AC power is shared** with devices that have coils such as relays, solenoids, or other inductors, each coil must have an MOV, AC Transorb, or other spike snubbing device across each of the shared coils. Without these snubbers, coils produce very large voltage spikes when de-energizing that can cause malfunction or destruction of electronic circuits.
- 3) **If the 24 volt DC power is shared** with devices that have coils such as relays, solenoids, or other inductors, each coil must have an MOV, DC Transorb, or diode placed across the coil or inductor.

The cathode, or banded side of the DC Transorb or diode, connects to the positive side of the power supply.

4) The secondary voltage should be isolated from earth ground, chassis ground, and neutral leg of the primary winding. Grounding should be to the system common only. Failure to follow these procedures can result in improper operation.

5) You should measure the actual voltage output of the secondary. If the output is not fully loaded you may read a higher voltage than the circuit board can handle.

The AX- ARM does NOT isolate the input signals from the output signals. Use the Analog Isolation Module (AX-IIM) if you need to isolate input signals from output signals.

### FACTORY CALIBRATION

The AX-ARM is set as follows:

No Attenuation to the Input Signal

Voltage Input Signal

Voltage Output Signal

Normal Acting Output Signal

No Offset to the Output Signal

Gain of 1 to the Output Signal (1:1).

The AX-ARM1 can be ordered calibrated to your specifications or you may follow the procedure below to set your own calibration.

Be sure to check the input, output, GAIN and OFFSET specifications of the AX-ARM. It is possible that the AX-ARM cannot re-scale to your requirements.

### CHECKOUT AND CALIBRATION

Complete the following steps to change the calibration of the AX-ARM. You will need a digital volt/current meter, a 24 VDC power supply and a voltage input signal simulator. (A 5K ohm or greater trim pot can be used as a voltage input signal simulator by connecting one end of the trim pot resistance winding to the (+) 24 of the power supply, the other end of the trim pot resistance winding to the (-) 24 of the power supply and the wiper end of the trim pot to the "IN" terminal of the AX-ARM.)

### EQUIVALENT CALIBRATION VOLTAGE

**Use a voltage signal for your input signal during calibration:** this makes both the procedure and the explanation easier. If you will require a current input when you are finished, use the equation below to find the equivalent calibration voltage to use during the calibration procedure:

Equivalent Calibration Voltage = Required Input Signal Amps x 250

For example, 1 VDC is the equivalent calibration voltage for a 4 milliamp input signal ( $1 = .004 \times 250$ )

or 5 VDC is the equivalent calibration voltage for a 20 milliamp input signal ( $5 = .020 \times 250$ ).

#### Step 1) Trim Pot Presets

Set all pots as follows to start (These are 25 turn trim pots with no hard stops; they may make a slight clicking sound at either end of their range):

Turn the following pots full clockwise: GAIN = gain of 1

FINE

OFFSET = 0 volts offset

REV = 0 volts reverse

Turn the following pot Full Counterclockwise: ATTN = no input signal attenuation)

#### Step 2) Jumper Shunt Presets

**J1- NORMAL OR REVERSE ACTING:** Set in "N" position for direct acting output signal. (If you require a reverse acting output signal, you will set this shunt in the "R" position in Step 7).

**J2 - OFFSET:** Set in the "O" position for no offset to the output. (If you will require a "+" or "-" offset, you will set this shunt in the appropriate position in Step 6).

**J3 IN - INCOMING SIGNAL VOLTAGE OR CURRENT:** Set in "E" position for voltage input. (If you require a current input, you will set this shunt in the "I" position **AFTER** you are finished with the calibration procedure).

Every effort has been taken in the production of this data sheet to ensure it's accuracy. Axio can not, however, accept responsibility for any damage, expense, injury, loss or consequential loss resulting from any errors or omissions. Axio has a policy of continuous improvement and reserves the right to change this specification without notice.

The offset adjustments simply shift the output signal range up or down from a “no offset” condition. For example, an output signal range in a “no offset “ condition is 3 to 15 volts. Adding an offset of 2 volts will now make the output signal range 5 to 17 volts. Subtracting an offset of 2 volts will now make the output signal range 1 to 13 volts.

Apply the minimum voltage input signal and read the minimum output signal on the meter. With the “OFFSET” jumper shunt “J2” in the “NO” position (from Step 6) no offset voltage will be added or subtracted from the output signal range.

If you need to shift the output signal range up, set the “OFFSET” jumper shunt “J2” in the “+” position and adjust the “OFFSET” trim pot until you increase the voltage reading on the meter to match the desired minimum output voltage. (Remember, this also increases the maximum output signal by the same amount.)

If you need to shift the output signal range down, set the “OFFSET” jumper shunt “J2” in the “-” position and adjust the “OFFSET” trim pot until you decrease the voltage reading on the meter to match the desired minimum output voltage. (Remember, this also decreases the maximum output by the same amount.)

#### **Step 7) Reverse Action Adjustments**

If you will require your output signal to reverse act, set jumper shunt “J1” in the “R” position. Apply the minimum voltage input signal and adjust the “REV” trim pot for the highest desired output signal. Check the low, mid-scale and high signal points to insure proper calibration.

#### **Step 8) Final Adjustments**

If you require a current input, set the “J3” IN jumper shunt in the “I” position. If you require a current output, set the “J3” OUT jumper shunt in the “I” position. Check operation of the ARM for desired signal rescaling and operation.

**ARM CALIBRATION WORKSHEET:** Fill in and circle answers.

1. Input: minimum \_\_\_\_\_ maximum \_\_\_\_\_ mA or VDC, Output: minimum \_\_\_\_\_ maximum \_\_\_\_\_ mA or VDC
  2. Is the input VDC? Yes/No. Is the output VDC? Yes/No
    - a) If yes to both, set jumper J3 (IN/OUT) to E and skip to step 5.
    - b) If no to both, set jumper J3 (IN/OUT) to I and skip to step 5.
    - c) If yes to only one, continue to step 3.
  3. Is current the input signal? If no, skip to step 4. If yes, perform the following:
    - a) Set J3 (IN) to I and (OUT) to E.
    - b) Multiply input minimum by 250 and enter value in "Input minimum" in step 5a.
    - c) Multiply input maximum by 250 and enter value in "Input maximum" in step 5a.

**Example:** minimum=4mA = .004 x 250 = 1 VDC and maximum=20mA = .020 x 250 = 5 VDC.
  4. Is voltage the input signal. If no, skip to step 5. If yes,
    - a) Set J3 (IN/OUT) to E. Output jumper will be changed to I in later steps.
    - b) Multiply output minimum by 250 and enter value in "Output minimum" in step 5b,
    - c) Multiply maximum by 250 enter value in "Output maximum" in step 5b.

**Example:** minimum 4mA = .004 x 250 = 1 VDC and maximum 20mA = .020 x 250 = 5 VDC.
  5. Enter mA, VDC or equivalent values below. **Note:** Do not mix voltage and current.
    - a) Input minimum \_\_\_\_\_ Input maximum \_\_\_\_\_ maximum-minimum = Input span \_\_\_\_\_
    - b) Output minimum \_\_\_\_\_ Output maximum \_\_\_\_\_ maximum-minimum = Output span \_\_\_\_\_
  6. Preset trimpots: Turn 20 times or until it clicks.  
Turn Clockwise - Gain, Fine, Offset and Reverse  
Turn Counter clockwise – Attenuation
  7. Make all connections including signal generator and multi-meter. Apply power (24 VAC or VDC).
  8. Set jumpers J2 to 0 and J1 to N
  9. First test: input a 50% signal. Is the input equal to or close to the output?  
If yes, proceed to step 10.  
If no, return to step 7.
- Note: Min, max and span values are found in step 5.
10. Supply the "input span" signal or equivalent to the input. (Refer to step 5).
    - a) If the "input span" is less than "output span", turn the gain or fine trimpot until the output is equal to the "output span" signal.
    - b) If the "input span" is greater than "output span", turn the attenuation trimpot until the output is equal to the "output span" signal.
  11. Setting the offset jumper:
    - a) If the "input minimum" is greater than "output minimum" Set J2 to (-). Skip to 12.
    - b) If the "input minimum" is less than "output minimum" Set J2 to (+). Skip to 12.
    - c) If the "input minimum" is equal to "output min" Leave J2 alone and skip to step 12.
  12. Supply the "input minimum" signal or equivalent to the input. Adjust the offset trimpot until the output reads the same as "output minimum".
  13. Is signal reverse acting? If not skip to step 14. If yes, refer to following:
    - a) Set J1 to R.
    - b) Supply "input minimum", or equivalent, and adjust the Rev trimpot until reading is equal to output maximum.
  14. If the output is current. Set J3 (out) to I and reset meter to current. ( $V_{out} / 250 = mA$ ).
  15. Check the low, midscale and high signal points to check output for proper calibration. Fine calibration adjustments may be made now.